

**Tracked Dumper**  
HIGH DUMP | SWIVEL DUMP

**TC100d**

# EVOLUTION

 **MESSERSSI** spa

MADE IN ITALY



Since 1994

**Semco**<sup>®</sup>  
Equipment Sales

[www.semco-group.com.au](http://www.semco-group.com.au)



## GENERAL FEATURES

Tracked undercarriage for overcoming obstacles.

Tracked undercarriage with hydrostatic transmission and oscillating rollers in the center of the track.

The patented layout of the rubber track provides a wide area and a low ground pressure, high stability and an excellent driving comfort in all conditions of use.

Water-cooled Diesel engine with electric start

Hydrostatic transmission.

With piston pumps with variable displacement and orbital motors  
Steering by the rotation of the tracks.

Tracked undercarriage suitable for different specific applications.

# Tracked Dumper

HIGH DUMP | SWIVEL DUMP

# TC100d

# EVOLUTION

**MESSERSI** spa

MADE IN ITALY

## TECHNICAL DATA

		SWIVEL DUMP	HI-DUMP
		TC100d	TC100d
Operational weight (without operator)	kg	775	845
Skip capacity			
- heaped (SAE standard)	m <sup>3</sup>	0,45	0,43
- struck (SAE standard)	m <sup>3</sup>	0,36	0,37
- liquids	m <sup>3</sup>	0,25	0,24

TC100 - TC100d		
Max payload undercarriage	kg	1000
Diesel Engine	type	Kubota Z482
Displacement	cm <sup>3</sup>	479
Cylinder	n°	2
Max. Power	kW/Hp	9.6/13 @ 3600 rpm
Cooling	type	Water
Battery	type	12V - 55 Ah
Variable displacement piston pumps for driving		2x30 lt/min @ 230 bar
Gear pump for services		1x7 lt/min @ 160 bar
Track width	mm	180
Track tensioning	type	Spring and screw
Specific ground pressure: empty/loaded	kg/cm <sup>2</sup>	0.18/0.48
Max speed	km/h	4.0
Max.gradient capability with operational loading	%	62
Fuel tank capacity	lt	9.7
Hydraulic oil tank capacity	lt	22.1



## OVERALL DIMENSIONS

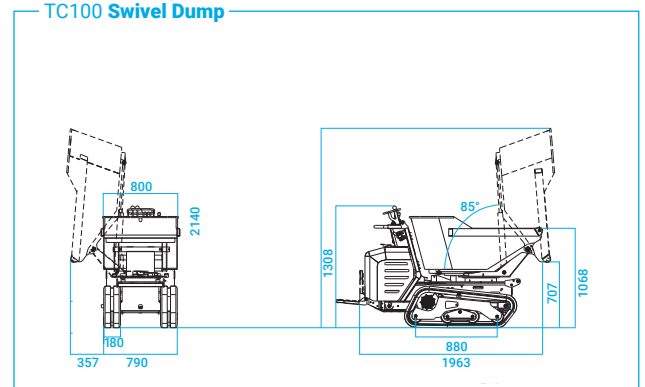
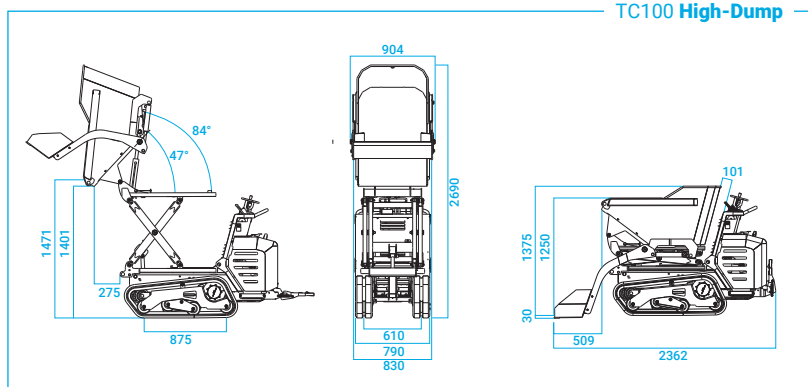

**PH: 1800 685 525**

**55-63 Kurrajong Rd, St Marys NSW**

**www.semco group.com.au**

**Semco**®  
Since 1994  
Equipment Sales

SYDNEY (HQ) | MELBOURNE | QUEANBEYAN  
GOULBURN | NEWCASTLE | BRISBANE