

Tracked Dumper

SWIVEL DUMP

TC120d

EVOLUTION

MESSERSI spa

MADE IN ITALY



Since 1994

Semco®

Equipment Sales

www.semco-group.com.au

GENERAL FEATURES

Tracked undercarriage for overcoming obstacles.

Tracked undercarriage with hydrostatic transmission and oscillating rollers in the center of the track.

The patented layout of the rubber track provides a wide area and a low ground pressure, high stability and an excellent driving comfort in all conditions of use.

Water-cooled Diesel engine with electric start

Hydrostatic transmission.

With piston pumps with variable displacement and orbital motors
Steering by the rotation of the tracks.

Tracked undercarriage suitable for different specific applications.

Tracked Dumper
SWIVEL DUMP

TC120d

EVOLUTION

MESSERSI^{spa}
MADE IN ITALY

TECHNICAL DATA

		SWIVEL DUMP
		TC120d
Operational weight (without operator)	kg	800
Skip capacity		
- heaped (SAE standard)	m ³	0,45
- struck (SAE standard)	m ³	0,36
- liquids	m ³	0,25

		TC120d
Max payload undercarriage	kg	1200
Diesel Engine	type	Kubota D722
Displacement	cm ²	719
Cylinder	n°	3
Max. Power	kW/Hp	14.9 /20 @ 3600 rpm
Cooling	type	Water
Battery	type	12V - 55Ah
Variable displacement piston pumps for driving		2x30 lt/min @ 230 bar
Gear pump for services		1x21 lt/min @ 170 bar
Track width	mm	180
Track tensioning	type	Spring and screw
Specific ground pressure: empty/loaded	kg/cm ²	0.18/0.52
Max speed	km/h	3.0/5.0
Max.gradient capability with operational loading	%	62
Fuel tank capacity	lt	9.7
Hydraulic oil tank capacity	lt	25.4



OVERALL DIMENSIONS

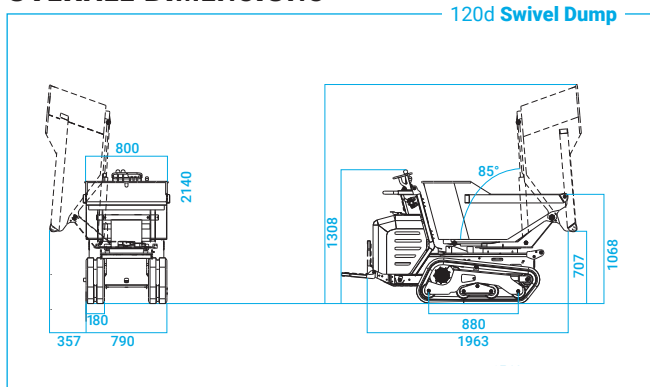

PH: 1800 685 525

55-63 Kurrajong Rd, St Marys NSW

www.semco^{group}.com.au

Since 1994

Semco[®]
Equipment Sales

SYDNEY (HQ) | MELBOURNE | QUEANBEYAN
GOULBURN | NEWCASTLE | BRISBANE