

ELECTRIC HYDRAULIC COMPACT EXCAVATOR

takeuchiTM

From World First to World Leader

TB20e



Operating Weight: 1,930 kg

TOUGH, POWERFUL, RELIABLE



Electro-Hydraulic Joysticks



4.3" Color Display



Load Sensing System



TFM

As Takeuchi looks to the future and how we can be better stewards of the environment, we have once again tapped into our spirit of creation and innovation and developed the all-electric TB20e compact hydraulic excavator. The beauty of the TB20e is that it is a zero emission and low noise level compact excavator with the same performance features and capabilities as diesel powered machines in the same class.

It is ideal for use in areas that have both noise and emissions restrictions such as in and around schools, neighborhoods, hospitals, and municipalities. An onboard charger is able to not only charge the machine during breaks and at the end of the workday, but it also allows the operator to work while tethered. Also available is

an offboard charger that can be used to charge the TB20e in a relatively short amount of time. The TB20e is work ready and demonstrates its Takeuchi pedigree through and through whether it be its rugged all steel construction and heavy-duty design, standard long arm, or the retractable undercarriage which enables the TB20e to work in confined areas and pass through narrow openings.

For customers wanting to reduce their carbon footprint while still being able to get jobs done on time and with minimal downtime, the Takeuchi TB20e provides an abundance of productivity and a reduction of overall operating costs that are associated with traditional diesel-powered construction equipment.



Spacious and Uncluttered Automotive Styled Interior

Product Features & Specifications

ZERO EMISSION ELECTRIC POWER

- 24.7 kWh Lithium-Ion Battery
- 100% Battery Powered with Zero Emissions
- Reduced Sound and Vibration Levels
- Over 60% CO2 Savings*
- Over 50% Reduction in Service and Operation Costs*
- ECO Mode
- Emergency Stop Switch
- Safety Start System (Left Console)

ELECTRICAL

- 4.3" Multifunction Color Display
- Weather Resistant Rocker Switches
- LED Light Package ; Boom, Front and Rear Canopy
- Travel Alarm (optional)
- 12V Battery Disconnect Switch
- TFM (Takeuchi Fleet Management)
- Hour Meter / Trip Meter

CHARGING

- Portable Off-board Charger for Quick Charge: 340~460V (3-Phase)** (optional)
- On-board Charger for Operation while Charging: 95~265V (Single Phase)

OPERATOR'S STATION

- ROPS/TOPS/OPG (Top Guard, Level I)
- 12V Power Outlet
- Suspension Adjustable Seat
- 2" Retractable Seat Belt
- Foldable Travel Pedals
- Boom Swing Pedal with Foldable Guard

UNDERCARRIAGE AND FRAME

- Triple Flanged Track Rollers
- Hydraulically Retractable Track Frame (980 mm to 1,300 mm)
- Adjustable Width Backfill Blade
- 2-Speed Travel with Automatic Shift
- Wraparound Protective Counterweight
- 230 mm Rubber Tracks

WORKING EQUIPMENT

- Boom Swing
- Cushioned Boom and Swing Cylinders
- Top Mount Boom Cylinder
- Boom Swing Stopper
- 1,130 mm Arm
- Arm Holding Valve (optional)
- Boom Holding Valve with Lift Alarm (optional)
- ISO/SAE Pattern Change Valve via Display
- Lifting Point on Bucket Linkage (optional)

ELECTRO-HYDRAULIC

- 2-Electric Motors
- Load Sensing System for Operation
- Electro-hydraulic Joysticks
- Service Port 1 with Proportional Controls
- Detent for Service Port 1
- Service Port 2 with Proportional Controls (optional)
- Service Port 3 for Quick Hitch (optional)
- Service Port 4 with Proportional Control (optional)
- Service Ports Plumbed to Arm
- Steel Hydraulic Tank w/Fluid Sight Gauge
- Pilot Accumulator
- Air Breather, Hydraulic Tank
- Auto Tank (Tank circuit is automatically opened)
- Adjustable Hydraulic Flow for Service Port 1, 2 and 4

TAKEUCHI FLEET MANAGEMENT

- Minimize Downtime
- Remote Diagnostics
- Utilization Tracking
- Proactive Maintenance
- Control Costs
- Geofencing



Environmentally Friendly



Flexible Charging Solutions

* Reductions of CO2 emissions and service/operation costs are compared with a conventional product of the same class in Japan.

** Functions may not be available in all countries, so please consult your Takeuchi dealer for details.

OPERATING PERFORMANCE

Operating Weight - Canopy	1,930 kg
Bucket Capacity (Heaped)	0.038 m ³
Slew Speed	7.6 min ⁻¹
Travel Speed	
1st	2.1 km/h
2nd	4.0 km/h
Gradeability	15°
Ground Pressure	32.1 kPa
Maximum Bucket Breakout Force	13.7 kN
Maximum Arm Digging Force	8.1 kN
Traction Force	20.7 kN
Boom Swing Angle (Left/Right)	78° / 49°

LITHIUM ION BATTERY

Battery Capacity	24.7 kWh
Battery Voltage	73V
Continuous Working Time	Up to 8 Hours*
Battery Charge Hours	20-80%
Off-board Charger @ 400V	2 hours
On-board Charger @ 200V	6 hours
Input Voltage When Charging	
Off-board Charger	340-460V**
On-board Charger	95-265V

LEAD-ACID BATTERY

Battery Capacity (IEC 60095-1)	12V-43A·h**
--------------------------------	-------------

HYDRAULIC SYSTEM

P1	
Flow Rate	50.7 L/min
Relief Pressure	20.6 MPa
P2	
Flow Rate	10.0 L/min
Relief Pressure	19.6 MPa
Service Port 1	
Flow Rate	34.0 L/min
Hydraulic Pressure	18.0 MPa
Service Port 2	
Flow Rate	11.0 L/min
Hydraulic Pressure	20.6 MPa
Service Port 3	
Hydraulic Pressure	19.6 MPa
Service Port 4	
Flow Rate	11.0 L/min
Hydraulic Pressure	20.6 MPa
Hydraulic Reservoir Capacity	14.1 L
Hydraulic System Capacity	24.0 L

SAFETY and HEALTH

Vibration Levels	
Hand / Arm	≤2.5 m/s ²
Body	≤0.5 m/s ²
Noise Level	
Sound Power Level	L _{WA} 80 dB

*Under Normal Condition

**Values in this document are for Europe.



LED Working Lights

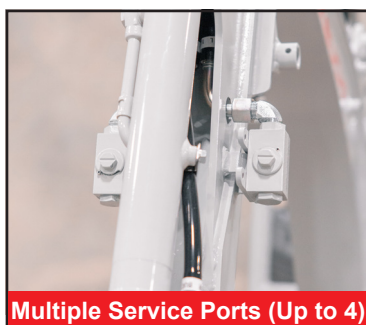

Multiple Service Ports (Up to 4)

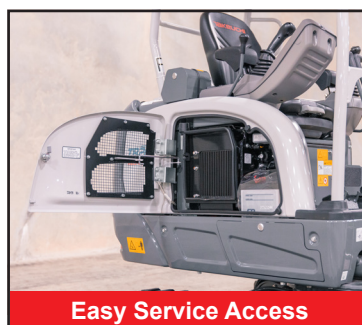

Easy Service Access



Retractive Undercarriage

TB20e Compact Excavator

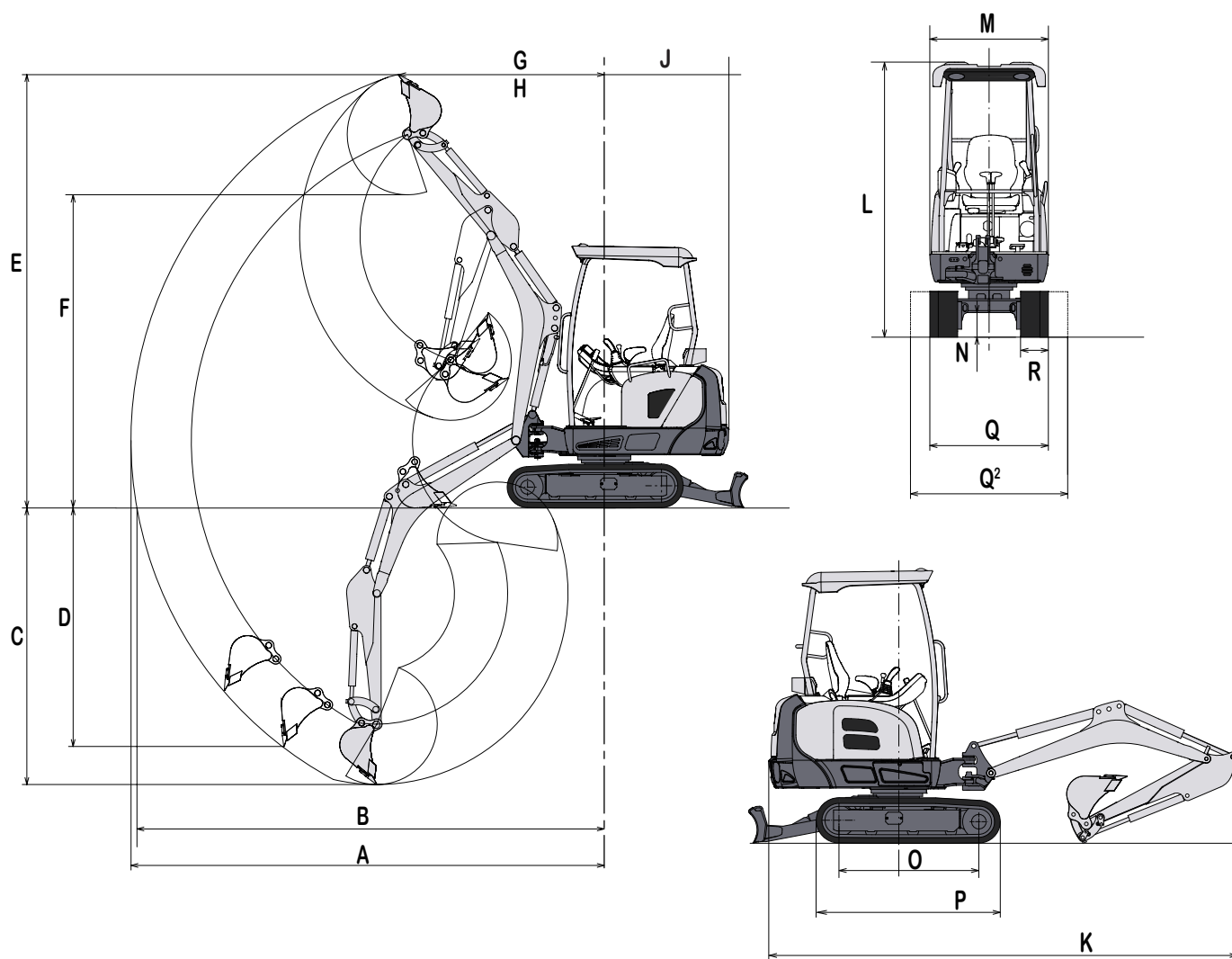

MACHINE DIMENSIONS

1,130 mm Arm

A	Maximum Reach	4,090 mm
B	Maximum Reach at Ground Level	4,035 mm
C	Maximum Digging Depth	2,390 mm
D	Maximum Vertical Digging Depth	2,060 mm
E	Maximum Height of Cutting Edge	3,740 mm
F	Maximum Dumping Height	2,705 mm
G	Front Swing Radius	1,480 mm
H	Front Swing Radius with Boom Offset	1,155 mm
J	Slew Radius	1,075 mm
K	Overall Length	3,880 mm
L	Overall Height	2,280 mm
M	Upper Structure Overall Width	985 mm
N	Ground Clearance	205 mm
O	Crawler Base	1,155 mm
P	Crawler Overall Length	1,520 mm
Q	Crawler Overall Width - Crawler Retracted	980mm
Q ²	Crawler Overall Width - Crawler Extended	1,300 mm
R	Crawler Shoe Width	230 mm



© 2023 Takeuchi MFG. Co., Ltd. All Rights Reserved. In accordance with our established policy of continued improvement, specifications and features are subject to change without notice. Pictures may show options other than standard equipment.

FORM: TB20e Compact Excavator Spec Sheet - Sept. 2023

TAKEUCHI[™]
From World First to World Leader