

WHEELED EXCAVATOR

takeuchiTM
From World First to World Leader

TB370W



Operating Weight: 7,900 kg

TOUGH, POWERFUL, RELIABLE



8" Touch Screen Display



Intuitive Operation



Multi Function Grips (OPT)



Pressure Adjustment (OPT)

The TB370W wheeled excavator provides owner/operators with a highly versatile option that combines powerful excavating performance with on-road capabilities, making it ideal for shorter-term, faster-paced projects. With all the unique benefits of a wheeled unit, including higher travel speeds and the auto cruise control which enables operators to set and adjust their travel speeds by pressing a button or operating toggle switch (equipped on optional multi function grips), TB370W features a wider operating range with a 2-piece variable angle boom, precise hydraulic operations using load sensing hydraulic system and up to four auxiliary hydraulic circuits for improved productivity. In addition, an operator can select their preferred working mode among three options, standard, ECO and ECO plus. ECO plus mode automatically changes the working mode between standard and ECO depending on its load for the best efficiency and ECO friendly.

Inside the cab configuration, an 8" multifunction touch screen display places a wide range of functions at the operator's fingertips, including the DAB radio with Bluetooth functionality and HVAC settings. Well positioned switches ensure an easy access to the variable functions and a jog dial function linked with the display helps with operator's intuitive operation. Optional multi-function grips allow to assign the often used functions to buttons on it according to owner's preference.



Completely Redesigned Automotive Styled Interior with Intuitive User's Operation

Product Features & Specifications

ENGINE

- EU Stage V / EPA Tier 4 Emission Compliant
- DOC+DPF Exhaust After Treatment
- Automatic Fuel Bleed System
- Double Element, Air Cleaner
- Automatic Deceleration
- Working Modes: Standard, ECO and ECO Plus (automatically changes working mode between standard and ECO depending on the load)
- Engine Safety Start System on the Left Console
- Engine Auto Stop
- Fuel Supply Pump w/ Reel System

ELECTRICAL

- 8" Color Touch Screen Display
- Multi-Switch Control Panel & Jog Dial Control
- E/H Control for Dozer Blade, Boom Swing and Adjust Cylinder
- LED Light Package ; Right Cover, Boom, Front Cab, and Rear Cab
- LED Head Lights, Turn Signals and Tail Lamps
- TFM (Takeuchi Fleet Management, GPS)
- Rear View Monitor
- Arm Position Lamp (optional)
- Back Buzzer (optional)
- TSS (Takeuchi Security System, Immobilizer) (optional)*
- 270° View Monitor (optional)

OPERATOR'S STATION

- ROPS/TOPS/OPG (TOP Guard, Level I)
- Air Suspension Seat with Heat
- Tilttable Steering Wheel
- 2" Retractable Seat Belt
- Cab with Automatic Climate Control System, Windshield Wiper and Washer, Skylight, Sunshade and DAB Radio with Bluetooth
- Smartphone Holder with USB Port
- Rain Guard (Optional)
- OPG Level II Tilttable Roof Guard (Optional)
- OPG Level II Front Guard (Optional)

UNDERCARRIAGE AND FRAME

- 2 Wheel Steering (2WS)
- 7.50-15, 16 PR Twin Tires
- Auto Cruise Control
- Heavy Duty Dozer Blade
- Check Valve, Dozer Blade
- Cylinder Cover for Dozer Blade
- Large Wrap Around Counterweight
- Parking Brake
- Ram Lock
- Diff Lock
- Tool Box
- Mud Guards (optional)
- Auto Digging Brake (optional)
- Outrigger (optional)
- Cylinder Covers for Outrigger (optional)
- Additional Tool Box (optional)

HYDRAULIC

- Load Sensing Hydraulic System
- Hydraulic Joystick Controls
- Proportional Control for Service Port 1
- Detent for Service Port 1
- Proportional Control for Service Port 2
- Service Port 3 for Quick Hitch (optional)
- Proportional Control for Service Port 4 (optional)
- Independent Service Port 4 with Multi-Functional Grips (optional)
- Auxiliary Hydraulic Circuit Plumbed to Arm
- Adjustable Auxiliary Flow for Service Port 1, 2, and 4
- Pilot Accumulator
- Auto Tank for Service Port 1
- Service Port Performance Package ; Auto Pressure Release for SP1 & SP2, Pressure Adjustment for SP1 & SP2 and High Pressure for SP1 (optional)

WORKING EQUIPMENT

- 2-Piece Variable Angle Boom
- Cushioned Boom, Arm and Swing Cylinders
- Boom Swing Stopper
- Boom Holding Valve w/ Lift Alarm
- Arm Holding Valve
- Adjust Cylinder Holding Valve
- Lifting Point of Bucket Linkage (optional)

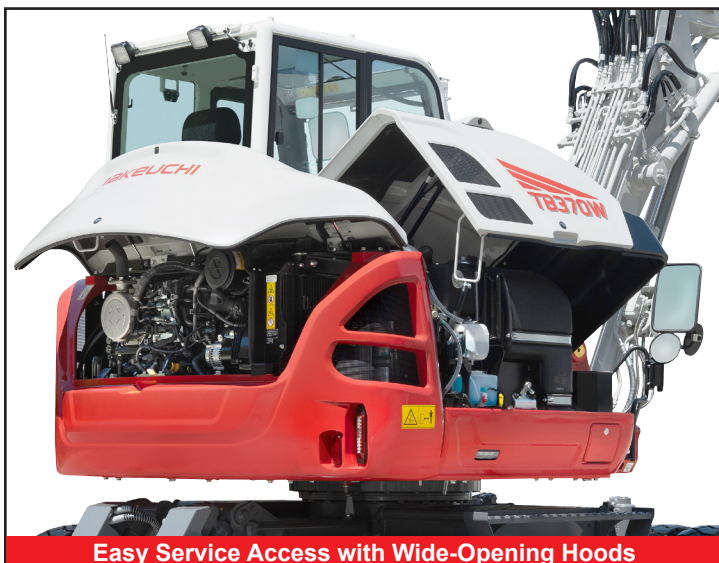

Easy Service Access with Wide-Opening Hoods



Tilt-Up Cabin Delivering Excellent Serviceability

*Functions may not be available in all countries, so please consult your Takeuchi dealer for details.

OPERATING PERFORMANCE

Operating Weight	
w/ Dozer Blade Only	7,555 kg
w/ Dozer Blade and Outrigger	7,900 kg
Bucket Capacity (Heaped)	0.180 m ³
Slew Speed	8.8 min ⁻¹
Travel Speed	
Low Speed 1	2.8 km/h
High Speed 1	10.0 km/h
Low Speed 2	6.5 km/h
High Speed 2	29.6 km/h
Gradeability	30°
Maximum Bucket Digging Force	48.4 kN
Maximum Arm Digging Force	29.4 kN
Traction Force	61.7 kN
Boom Swing Angle (Left/Right)	79° / 51°

ENGINE

Model	Kubota / V2607-TE5AB
Rated Output (ISO 14396)	54.6 kW / 2,700 min ⁻¹
Maximum Torque	221.7 Nm / 1,600 min ⁻¹
Displacement	2,615 ml
Alternator	12V - 1.08 kW
Battery (IEC 60095-1)	12V - 90 A·h

FLUID CAPACITY

Engine Lubrication	10.2 L
Cooling System	12.0 L
Fuel Tank Capacity	110.0 L
Hydraulic Reservoir Capacity	65.5 L
Hydraulic System Capacity	149.0 L

HYDRAULIC SYSTEM

Work Equipment	
Flow Rate	160.0 L/min
Relief Pressure	24.5 MPa
Slew	
Flow Rate	46.2 L/min
Relief Pressure	26.0 MPa
Travel	
Flow Rate	80.0 L/min
Relief Pressure	35.0 MPa
Service Port 1	
Flow Rate	120.0 L/min
Hydraulic Pressure	21.0 MPa
Hydraulic Pressure (Optional)	24.0 MPa
Service Port 2	
Flow Rate	55.0 L/min
Hydraulic Pressure	21.0 MPa
Service Port 3	
Hydraulic Pressure	21.0 MPa
Service Port 4	
Flow Rate	55.0 L/min
Hydraulic Pressure	21.0 MPa

SAFETY and HEALTH

Vibration Levels	
Hand / Arm	≤ 2.5 m/s ²
Body	≤ 0.5 m/s ²
Noise Level	
Sound Power Level	L _{WA} 97 dB



Sliding Window on the Door

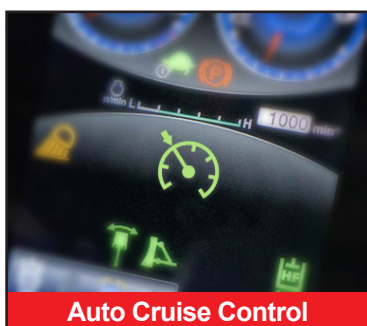

Auto Cruise Control

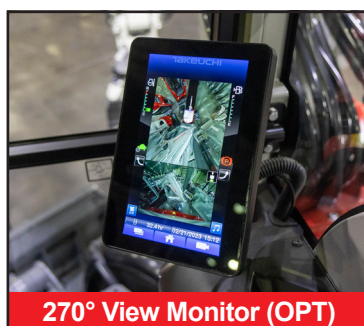

270° View Monitor (OPT)



Tiltable Roof Guard (OPT)

TB370W Wheeled Excavator

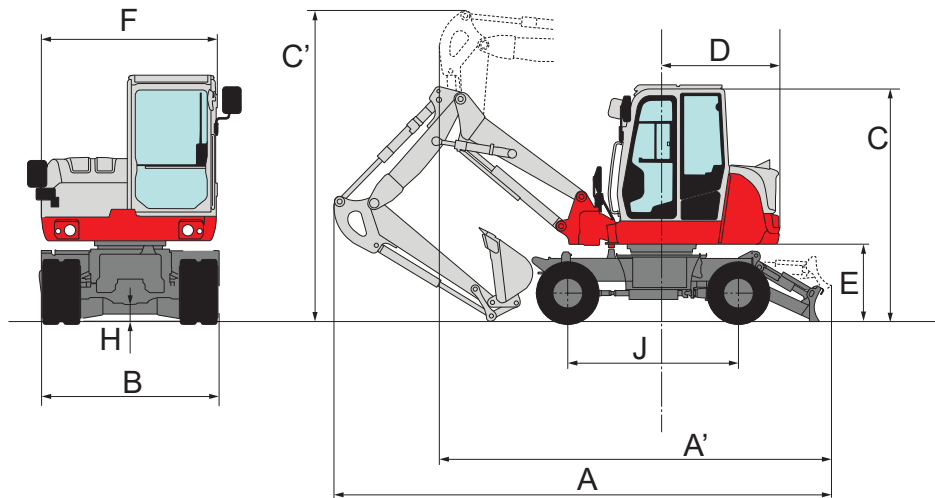

Dozer Blade Only

Dozer Blade and Outrigger

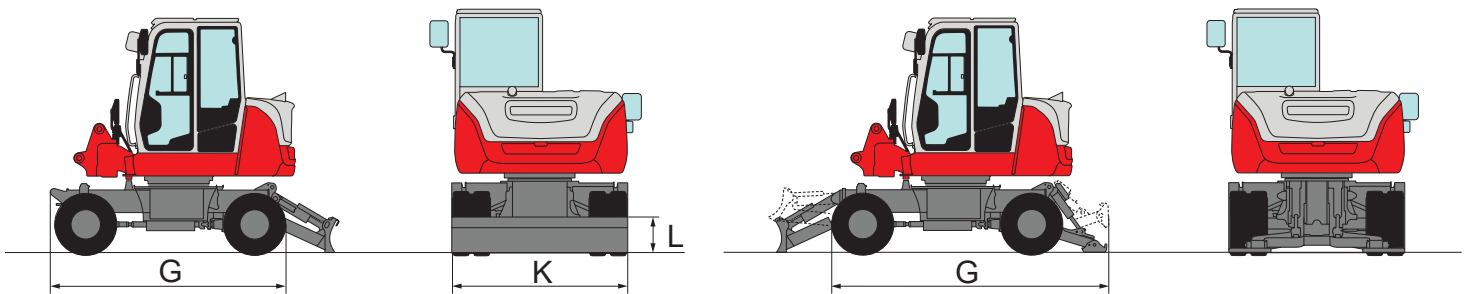

MACHINE DIMENSIONS

A Overall Length	* 6,025 mm / 6,350 mm
A' Overall Length (Road Travel Posture)	* 4,770 mm / 4,625 mm
B Overall Width	2,100 mm
C Overall Height	** 2,890 mm / 2,920 mm
C' Overall Height (Road Travel Posture)	3,830 mm
D Slew Radius	1,450 mm
E Clearance Height Under Upper Structure	955 mm
F Overall Width of Upper Structure	2,060 mm
G Overall Length of Undercarriage	* 2,925 mm / 3,440 mm
H Ground Clearance of Undercarriage	205 mm
J Wheel Base	2,100 mm
K Dozer Blade Width	2,100 mm
L Dozer Blade Height	430 mm

* Machines with dozer blade only / Machines with dozer blade and outrigger

** Machines without a roof guard / Machines with a roof guard

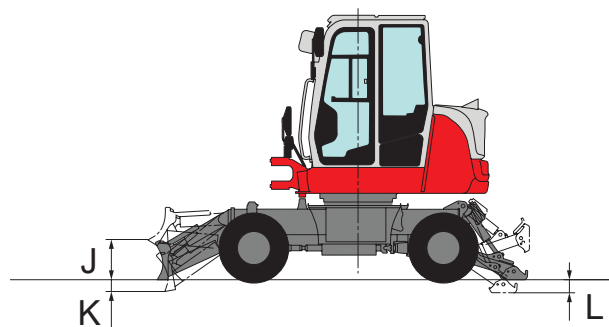
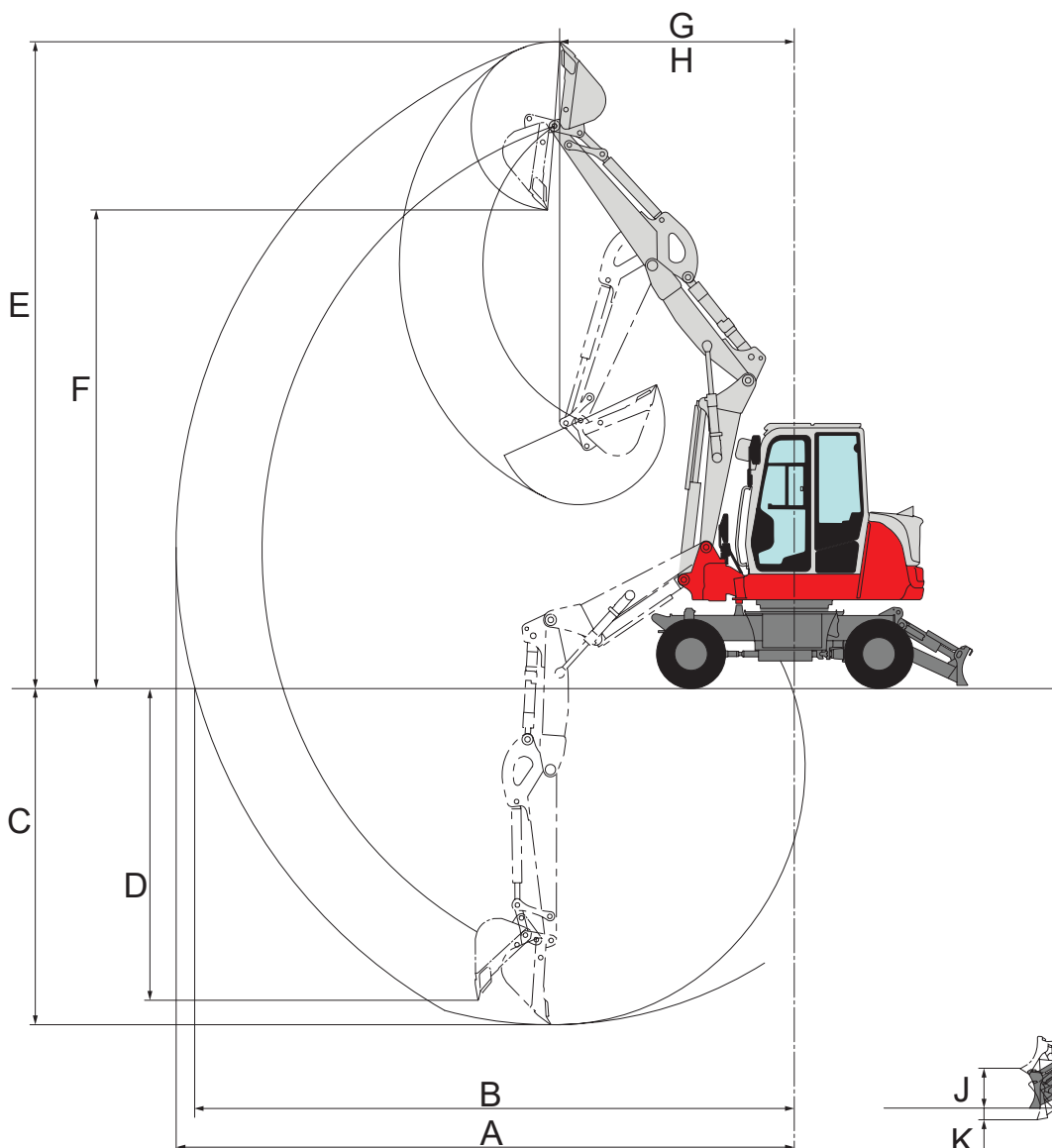

WORKING DIMENSIONS

A	Maximum Reach	6,905 mm
B	Maximum Reach at Ground Level	6,705 mm
C	Maximum Digging Depth	3,775 mm
D	Maximum Vertical Digging Depth	3,505 mm
E	Maximum Height of Cutting Edge	7,160 mm
F	Maximum Dumping Height	5,290 mm
G	Front Swing Radius	2,420 mm
H	Front Swing Radius with Boom Offset (Left / Right)	2,265 mm / 1,890 mm
J	Dozer Blade Maximum Lifting Height	445 mm
K	Dozer Blade Maximum Lowering Depth	130 mm
L	Outrigger Maximum Lowering Depth	145 mm